



The liquid level method for measuring settlements is based on the principle of communicating tubes. As early as 1933, v. TERZAGHI achieved a measuring accuracy of ± 0.01 mm with the help of a centric suspension and a micrometer indicator. Measurements are relative and are related to a random zero point. The measuring principle is illustrated in Fig. 1.

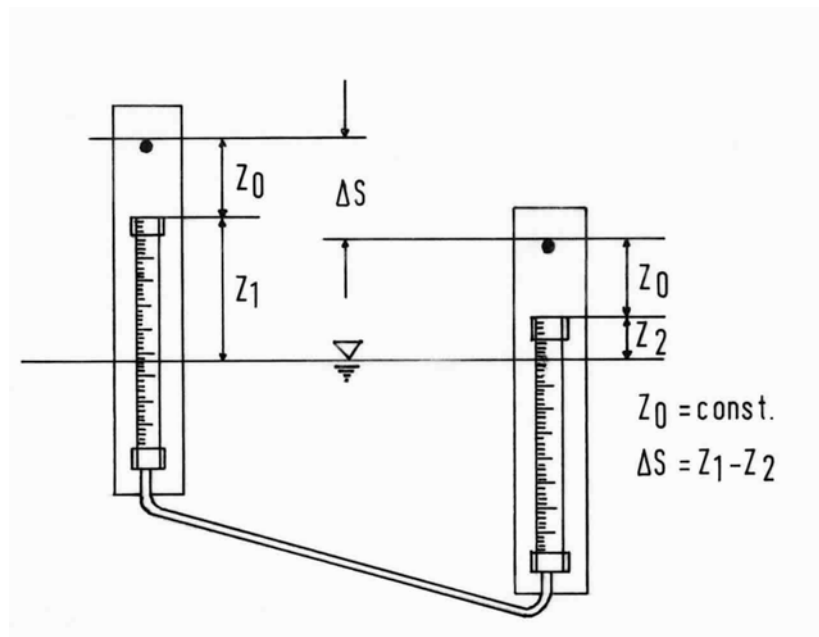

Fig. 1 Measuring principle of the liquid level method

Measurements are taken on the review minus preview principle and are confirmed with several readings in a forward and reverse pass. Reading accuracies of ± 0.001 mm are usually quoted nowadays by all manufacturers. Allowing for various sources of error we consider an actual measuring accuracy of ± 0.01 mm to be realistic. Possible sources of error are: Change of density of the gauge fluid due to fluctuations of temperature, changes of gravity at the measuring points, oscillations of the liquid column and formation of air bubbles in the tube system, fluctuations of air pressure, liquid losses from the reservoirs, thermal expansion of the measuring vessels, capillary forces in the measuring vessels, and mistakes when reading and levelling the liquid vessels.



Hydrostatic levelling is based on the tube level measuring principle. It consists of measuring the difference in height between a reference point and a mobile sensor. With the mobile sensor tubes of about 50 to 300 mm diameter can be monitored, in this manner the relative height of the tube to the reference point outside can be determined at specified intervals. If these measurements are joined together a complete profile of the tube can be established. The absolute height of the tube's starting point is established by precision levelling.

The method is used f. e. to monitor settlements of the contact surface of waste dumps and dams (see Fig. 1). By repeated measurements at specified intervals settlements may be revealed comparing the tube's profile of the follow-up measurement with that of the preceding measurement.

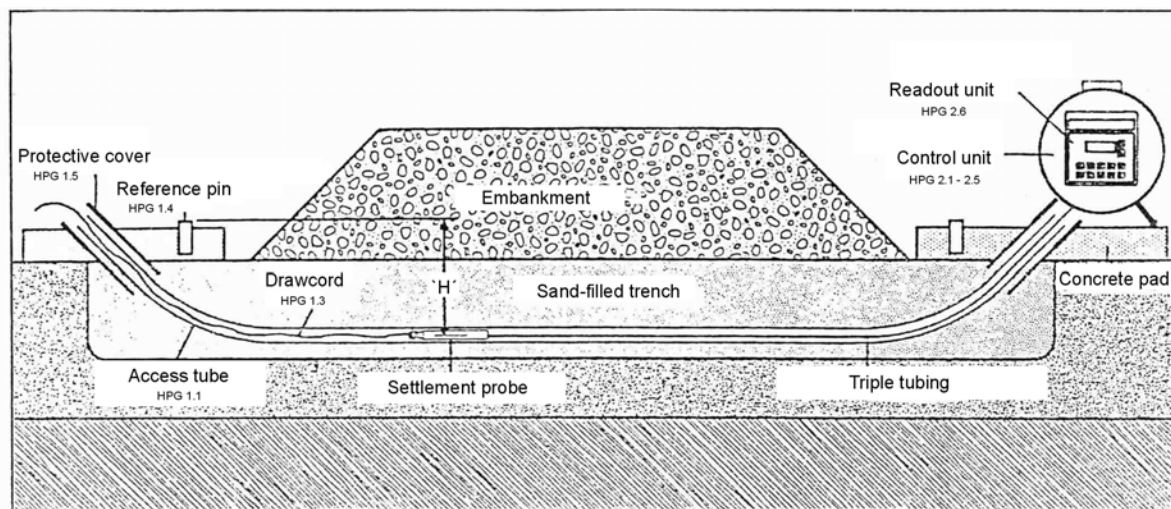

Fig. 1 Schematic arrangement of a measuring setup for levelling with a mobile hydrostatic profile gauge



The equipment comprises a digital readout unit, a cable reel with a built-in differential pressure transducer and a threefold tubing connected to a probe which is pulled through the access tube. The tubing which connects the readout and the probe consists of a protective tube with two nylon tubes. One of these tubes is filled with water and is constantly back-pressurised to overcome surface tension effects, and to prevent the formation of air bubbles.

The hydrostatic head at the probe depends on the difference in elevation “H” between the probe and the reference pin (see Fig. 1). This difference is measured with the aid of a differential transducer, the results are displayed directly in meters. The measured values can be stored in the digital readout unit and if necessary transferred directly to each computer with a V24-interface.

The system consists of the following components:

1. Probe

The probe is made of a metal housing where a water and an air tube are ending. A membrane guarantees the pressure compensation in the probe between air and water. The probe is pulled on a steel rope through the pipes where the measurements are to be taken. It is pulled back on the lines designed for. Normally slide rods are used, too.

2. Cable reel

In the cable reel a differential pressure transducer is mounted with the following technical data:

Measuring range:	± 1 bar
Working range:	± 10 m
Measuring accuracy:	0.1 percent FS
Measuring principle:	relative
Temperature range:	- 5 ... + 80 ° C

At the cable reel a data recording unit is placed.