



Displacements orthogonal to a bore hole are measured with tilt sensors (inclinometers) or permanently installed cross-shift measuring chains (deflectometers). To take measurements with the inclinometer, tubing is inserted in the bore holes. The annular gap between the tube and the bore hole wall is filled with cement mortar or damp material. The inclinometer, which is inserted in the bore hole on a measuring line, consists of a probe of either 0.5 or 1 m in length with two built-in pendulums arranged on mutually vertical planes. Spring-loaded rockers, each with two guide wheels, are positioned at both ends of the probe so that the guide wheel track fits exactly in the grooves of the tubing. The guide grooves ensure that the measuring axis of the inclinometer is the same for each measurement on moving through the bore hole in half or full meter steps during a measuring cycle. The measuring principle of a pendulum is illustrated in Fig. 1.

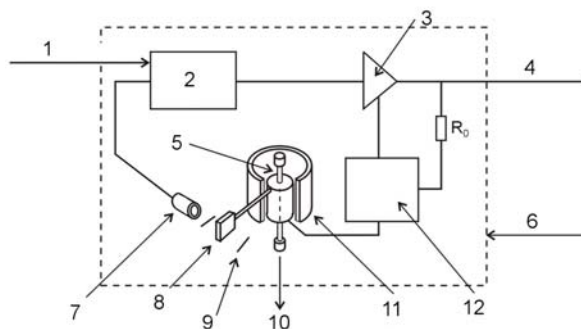

Fig. 1 Inclinometer pendulum with optical position sensor

1	Voltage	2	Electronics module
3	Amplifier	4	Output signal
5	Clamping band	6	Leakproof housing
7	Position sensor	8	Pendulum
9	Stop	10	Vertical axis
11	Motor	12	Filter

Any rock displacements occurring between two measurements will cause the inclination of the tubing to change. This change results in a different angle of inclination between the pendulum (vertical) and the measuring axis. The measured value is indicated as the sine of the angle of inclination or as a displacement in millimetres. For evaluation purposes, the individual measured values are joined together to form a progression. With careful measurements the measuring accuracy lies at $\pm 2 \times 10^{-4}$ of the measuring step ($\pm 0.2 \text{ mm}/1 \text{ m}$). Inclination measuring tubes can also be installed together with extensometers in the same bore hole, enabling displacements both parallel and transverse to the bore hole axis to be taken.



The inclinometer type Glötzl NMG is a probe for taking manual measurements of the angles of inclination in a guide tube. These measurements provide insight into movements in fills, e.g. dams, trafficway embankments, backfills behind retaining walls, and into movements in sliding masses, soil and rock.

The sensor works inside a guide tube which is inserted in boreholes or installed in fills. Hence it is possible to measure and record changes of a structure's inclination or the movement of layers.

1 Measuring sensor NMG

The sensor is made of rust-proof and acid-resisting material. For guidance inside the measuring tube, it is equipped with two spring-loaded rockers, each with two wheels.

Depending on the version, the sensor comes with either one or two tilt sensors (offset 90 °).

The tilt sensor is an accelerometer that responds to gravity. In this particular case, ± 1 g corresponds to an angle of ± 90 °. Since the output voltage follows the angle sinusoidally, an adjustment is required for bigger angles.

1.1 Versions

Type NMG 30/1	Measuring range $\pm 30^\circ$	Measuring axis A-A
Type NMG 30/2	Measuring range $\pm 30^\circ$	Measuring axes A-A and B-B
Type NMG H 30/0.5	Measuring range $\pm 30^\circ$	Horizontal inclinometer 0.5 m
Type NMG H 30/1	Measuring range $\pm 30^\circ$	Horizontal inclinometer 1.0 m

1.2 Technical data

Weight 2.2 or 3.2 kg	Measuring length	0.5 or 1.0 m
Linearity ± 0.05 % of result	Overall length	0.7 or 1.2 m
Hysteresis ± 0.001 % of result	Operating range	- 5 ° C to + 60 ° C
Temp. sensitivity $\pm 0.005\%$ FS/°C	Shock resistance	1500 g, 6 ms
Guide tube dia.	max. 70 mm	
	min. 35 mm	



2 Cable and accessories

- 2.1 Measuring line made of PUR/PVG, dia. 10 mm, with Kevlar core, 6 conductors, markings every 0.5 m, weight 0.15 kg per m
- 2.2 Cable reel type NMG 2 for max. 100 m cable, with slip ring contacts for two measuring axes, weight 7.0 kg
- 2.3 Adapter for inclination measuring tube NMF 48, with clamp for cable and guide wheel, weight 1.5 kg
- 2.4 Transport case for probe, readout unit and guide set. Dimensions: 680 mm long, 460 mm deep, 200 mm high.

3 Inclinometer guide tube

- 3.1 Guide tube with 4 grooves for the inclinometer, made of plastic or aluminium

Length 3000 mm
Overall diameter 55 mm
Inner diameter 48 mm
Weight/meter 1 kg

- 3.2 Coupling for the guide tube, made of plastic or aluminium

Length 300 mm
Overall diameter 65 mm
Weight 0.3 kg

- 3.3 Plug-type end cap type SV 48 with fixing screw

- 3.4 Slip-on end cap type KV 48 with fixing screw

- 3.5 Knock-in end plug type V 48, made of plastic or aluminium

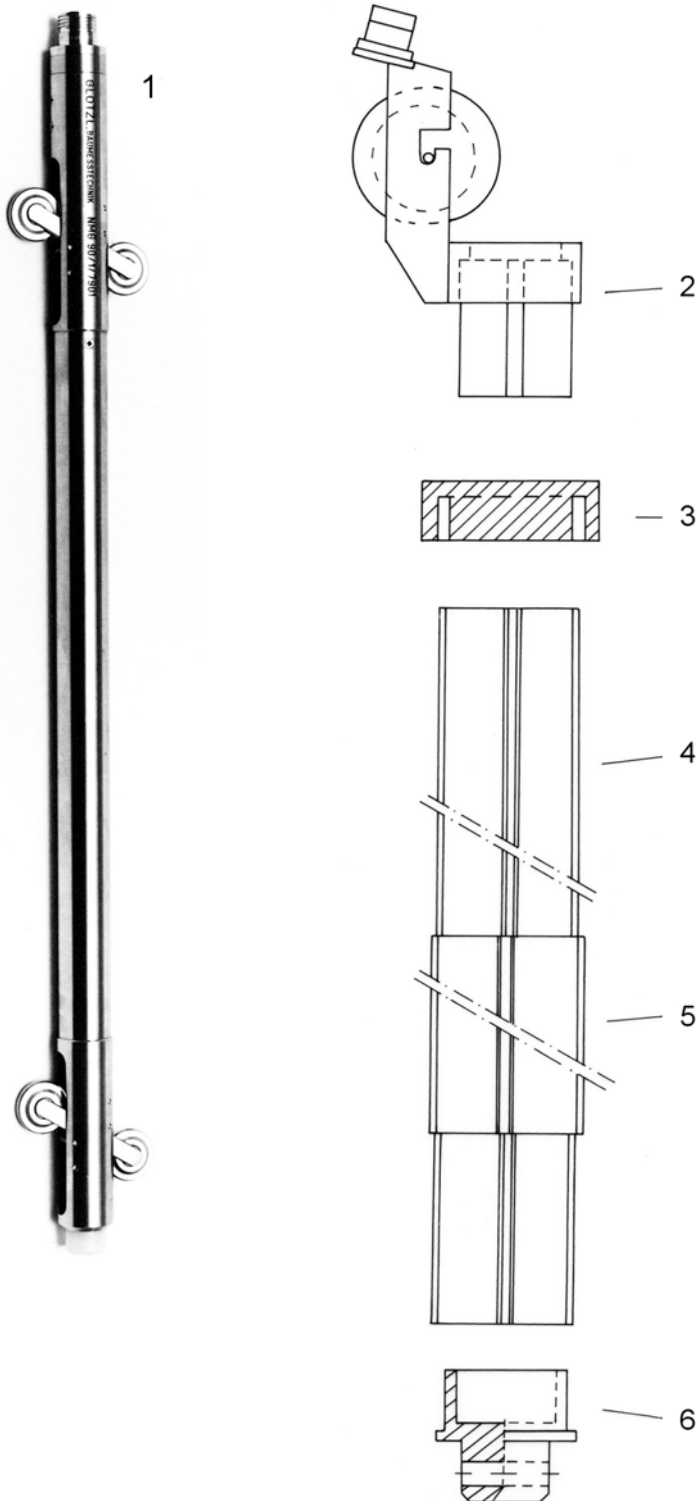

- 1 Inclinometer probe
- 2 Adapter for inclination measuring tube, with guide wheel and cable clamp
- 3 Slip-on end cap
- 4 Guide tube with 4 grooves, 3 m long
- 5 Coupling sleeve, 0.3 m long
- 6 End plug



4 Measuring unit VMG 14-1

The multimeter is used to measure nearly all individual standard probes, additionally it can also be used for line measuring methods (e. g. inclinometers). It has a charger and rechargeable, maintenance-free NiCD batteries, i. e. it can be operated independent of a mains outlet and can be reloaded either via the 230-V-mains or the car battery (12 V). The unit is programmable by keyboard or V24-interface. All measured data are stored and can be read out by the serial interface.

For the line measuring method variable programs which are easy to be operated from the user are available. With these programs the length of measuring steps, the total measuring length and the sort of measurement are defined.

Additionally the unit can be used as a temporary data recording system (data logger). A time program automatically calls the data by the connected multiplexer and saves them in an allocated file.

Front panel and keyboard assignment





(1) Display

Resolution (240 x 160) Pixels, filling factor $\approx 92\%$ at pixel grid 0.35 mm, effective display surface (88 x 60) mm², optimum viewing direction 10 ° from below, coated visual windows, monochromic, standard display black on white background, background lighting cold cathode fluorescence lamp (CFL), typ. luminosity 120 cd/m², automatic luminosity and contrast control, manual resetting of luminosity curve

(2) Keyboard

18 input keys, 1 switch on key, 1 switch off key, foil keyboard with bellied key surfaces. Height about 2.5 mm

Sensor supply

Two channels to be separately switched on and off

- bipolar voltage, controlled: +/- 2.5 - +/- 5.0 - +/- 10.0 - +/- 12.0 V
- bipolar voltage, uncontrolled: +/- 15.0 V
- unipolar voltage, controlled: +/- 12 V
- Current, controlled: 0.1 to 4.0 mA

Digital ports

- RS485 (sensor bus)
- V24 (modem DFÜ)

**Analog inputs**

Two channels, aligned in parallel, at one ADC input, about 10 Hz sensing rate over all channels together, resolution of digitalisation 16 Bit, self calibrating, channels switchable between current ($RE \approx 68 \Omega$) and voltage ($RE \approx 1M\Omega$).

Current measuring ranges: 0.5 – 1.0 – 2.0 – 5.0 – 10.0 – 25.0 mA

Voltage measuring ranges: 0.1 – 0.2 – 0.5 – 1.0 – 2.0 – 5.0 V

Power supply

- external: supply voltage 240 V_{AC}
- external: direct voltage 12 . . 24 V_{DC}
- internal: NiHM accumulators 6.2 V / capacity 7Ah / form R14

Dimensions and weight

Weight: 3.3 kg without current line

Dimensions: W = 190 mm, H = 120 mm, D = 210 mm

Software and memory size

Standard reading software for the communication PC – VMG 14-1

- 30.000 single measured data
- 250 projects
- 449 sensors
- 299 types

Case

Sturdy aluminium profile with carrying handle, protection type IP67 (splash proof); as supplementary accessory an artificial leather bag is available.



Charger

The Delta-U-Charger is equipped with an automatic charge control (integrated charge processor), end-of-charge control and excess temperature control.

The control recognizes the actual state of the accumulator and prevents an overcharge.

Accumulator and standby

When the unit is not used it has to be reloaded every 6 to 8 weeks.

Loading state – minimum 5.2 V, maximum 6.9 V. The actual loading state can be called in the menu „Unit setting“ under „battery state“.

At 4.6 V automatic switch-off due to deep discharge.

Operating time: on an average 18 hours (13 – 15 hours in case of inclinometer probe), dependent on sensor, without background lighting of display.

5 Installation materials and tools

- 5.1 Electric drill with storage battery and charger
- 5.2 Setting rivets for joining the guide tube to the coupling, pack of 100 pcs.
- 5.3 Rivet setting tongs
- 5.4 Water-proof sealing tape for sealing the joints, 50 mm wide and 10 m long

6 Inclinometer dummy probe

for checking the installed guide tube for obstructions

- 6.1 Type NMB 50 with 50 m steel rope and rope reel, 7.5 kg
- 6.2 Type NMB 100 with 100 m steel rope and rope reel, 8.5 kg



Sales Information

- 2.6.1.1 Measuring sensor NMG
 - 2.6.1.1.1 Inclinometer NMG 30/1,
measuring range +/- 30°, 1 measuring axis,
measuring length 0.5 m
 - 2.6.1.1.2 Inclinometer NMG 30/2,
measuring range +/- 30°, 2 measuring axes,
measuring length 0.5 m
 - 2.6.1.1.3 Horizontal inclinometer NMG H 30/0.5,
measuring range +/- 30°, 1 measuring axis,
measuring length 0.5 m
 - 2.6.1.1.4 Horizontal inclinometer NMG H 30/1,
measuring range +/- 30°, 1 measuring axis,
measuring length 1 m
- 2.6.1.2 Cable and accessories
 - 2.6.1.2.1 Measuring line made of PUR, d = 10 mm,
with core, markings every 0.5 m
 - 2.6.1.2.2 Cable reel NMK 2 for max. 100 m cable,
with slip ring contacts for 2 measuring axes
 - 2.6.1.2.3 Adapter for inclination measuring tube NMF 48
with clamp for cable and guide wheel
 - 2.6.1.2.4 Transport case for probe
(680 x 460 x 200)



- 2.6.1.3 Inclinometer guide tube
 - 2.6.1.3.1 Guide tube, made of ABS, with 4 grooves,
d = 55 mm, l = 3000 mm
 - 2.6.1.3.2 Coupling for guide tube, made of ABS, d = 65 mm,
l = 300 mm
 - 2.6.1.3.3 Plug-type end cap SV 48
with fixing screw
 - 2.6.1.3.4 Slip-on end cap KV 51
with fixing screw
 - 2.6.1.3.5 Knock-in end plug PV 48
for foot
- 2.6.1.5 Multimeter VMG 14.1
with data memory and measuring program
- 2.6.1.6 Installation materials
 - 2.6.1.6.1 Electric drill
with storage battery and charger
 - 2.6.1.6.2 Setting rivets d = 3 mm
 - 2.6.1.6.3 Rivet setting tongs
 - 2.6.1.6.4 Water-proof sealing tape,
50 mm wide, 10 m long
- 2.6.1.7 Inclinometer dummy probe NMB 50
l = 0.5 m, with 50 m steel rope and rope reel



When taking measurements with the inclinometer the value sets are automatically saved from the measuring instrument.

As a rule two series of measurements - we call them "standard" and "reverse" - are always conducted in one measurement setup. To distinguish between the two, A+ is engraved on the inclinometer probe as a marker. For the standard measurement series this marker is aligned with the direction A+ previously laid down in the field. For the reverse series, the probe is then turned through 180 °. The result should be a reading of equal magnitude but with the opposite sign.

With this approach it is possible, on the one hand, to calculate the mean error of each measuring step as the basis for making a correction should the mean error exceed a certain magnitude. On the other hand, it eliminates systematic errors, e. g. of the measuring sensor, by forming a mean value from two measurements with opposite signs.

Most inclinometer measurements are started at the bottom of a borehole, the assumption being that the borehole extends so far into the ground that no displacements take place in its deepest regions. Where this is not the case, measurements can be started at the top of the borehole, but then the absolute amount of displacement can only be determined if the starting point of the borehole is subjected to a geodetic survey.

Depending on the length of the probe, the measurement is taken in steps of 0.5 m or 1.0 m and is presented graphically in the form of a progression over the borehole depth and compared with the previous measurement series. A different form of presentation shows the time-related changes of inclination at select borehole depths (see the following figures).

We can supply the INCAL computer program, which can be run on any IBM-compatible PC, for the evaluation of inclinometer measurements.



PROJEKTNAME: Sondermülldeponie

Messstelle Nr.: I-2

Änderung des Messstreckenverlaufs bezüglich der Messung: 1 vom 08.10.90

——— Messung: 19 vom: 09.02.94 - - - - - Messung: 18 vom: 02.07.93

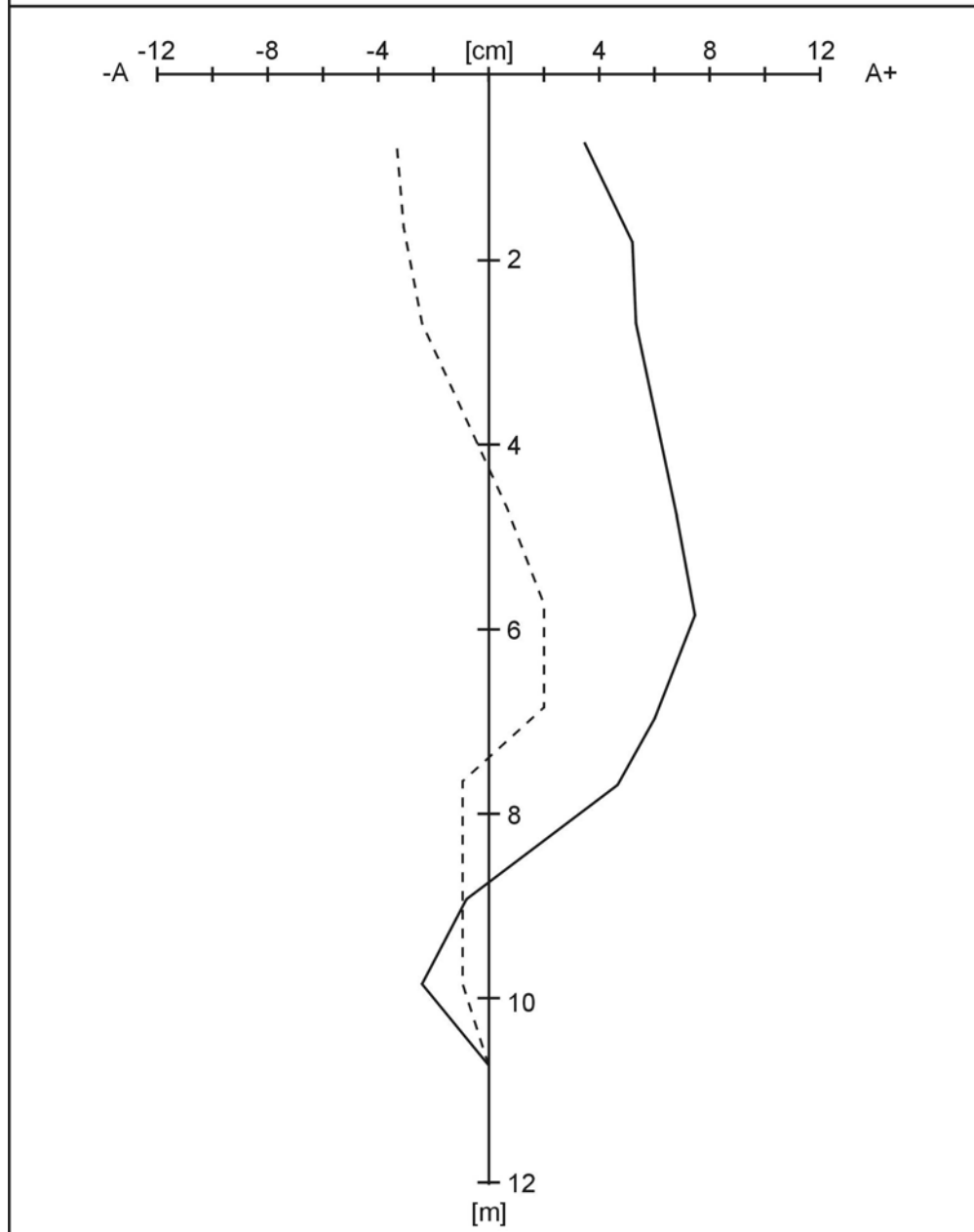



The Trivec probe allows to carry out inclinometer and probe extensometer measurements at the same time. It is a high-precision instrument for determining the three orthogonal components (x, y and z) of the displacement vector of vertical until subvertical measuring axes. The Trivec is a continued development of the sliding micrometer ISETH, which is additionally equipped with two inclinometer sensors (s. Fig. 1). This technology has been developed at the institute for road, railway and rock construction of the Technical University of Zurich, Switzerland. The high-precision measurements are achieved by means of bracing the probe with its spherical heads in the conical measuring marks.

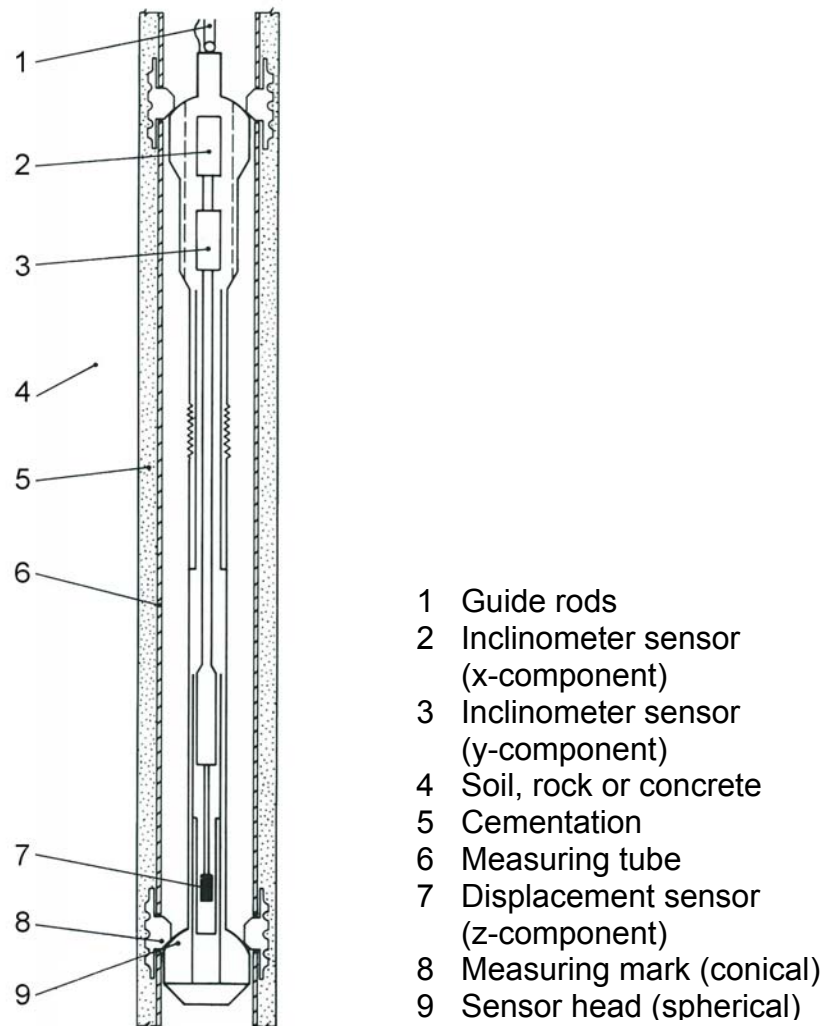

Fig. 1 Longitudinal section through borehole, measuring tube and probe



The measuring marks are installed in boreholes of a diameter of at least 100 mm in intervals of 1 m with the help of a plastic protective casing.

The measuring tube is positioned in the borehole, that the x and y axis of the instrument in measuring position is adapted to the measuring aim. Then the annular gap between borehole wall and casing is filled with cement mortar to connect rock and measuring marks.

The probe, weighing only 3 kg, is inserted into the casing and moved in a step-by-step fashion between the measuring marks which are at 1.0 m intervals. Both the spherically shaped probe heads and the measuring marks are provided with recesses which enable the probe to slide along the casing from one measuring mark to the next (sliding position). By rotating the probe 45 ° and pulling back on the guide rods, the probe's two heads are tensioned between two adjacent measuring marks (measuring position). Then rotate the probe 180 ° with the help of the guide rods and measure again.

High precision measurements can be achieved due to the excellent reproducibility of placing the probe. In the calibration frame an accuracy of $\pm 1 \mu\text{m}$ in z-direction and under field conditions $\pm 3 \mu\text{m}$ are attained. The high precision is due to the cone-sphere principle which defines the exact position of the sensor heads with respect to the measuring marks. The sensitivity of the instrument in terms of extension amounts to $1 \cdot 10^{-6}$ for the z-component, the measuring range is 20 mm. Probe and calibration device are provided with a temperature sensor to compensate length changes of the measured distance influenced by temperature.

The precise placing of the probe allows also an extremely high accuracy when measuring the x- and y-component with the aid of the two installed inclinometers. In case of careful measurement the accuracy is $\pm 0.05 \text{ mm} / \text{m}$ at a service temperature between 0 and 40° C.



Sales Information

- 2.6.3.1 Trivec measuring tube,
base length 1.0 m made of HPVC
outer diameter 60 mm,
inner diameter 50 mm
with telescopic coupling and conic
accurate stop
- 2.6.3.2 Cover made of HPVC for measuring tube, below,
with telescopic coupling and 0.5 m
measuring tube
- 2.6.3.3 Cover made of HPVC for measuring tube, above,
with flange $d = 150$ mm to fix the cable winch
and 0.5 m measuring tube